

RoHS  
Compliant

ZONE	EC N. N.O.	DESCRIPTION	DRAWING	DATE
A		INITIAL	林生财	2020.02.18

- MECHANICAL PERFORMANCE:
  - 1-1.INSERTION FORCE: 0.5~2.0kgf.
  - 1-2.EXTRACTION FORCE: 8~20N INITIAL,6~20N AFTER TEST;
  - 1-3.DURABILITY: 10000 CYCLES.
- ELECTRICAL PERFORMANCE:
  - 2-1. CURRENT RATING:5A MIN FOR VBUS,0.25A MIN FOR OTHERS VOLTAGE RATING: 20V MAX.
  - 2-2. ILLCP:
  - 2-3.INSULATION RESISTANCE: 100MΩ MIN
  - 2-4.DIELECTRIC WITHSTAND VOLTAGE,AC 100V FOR 1 MINUTE.
- The waterproof grade is IPX8(1.5m depth of water).
- PIN DEFINITION: (GND pins(A1,A12,B1,B2) and Mid Plate should connect together in PCB circuit.)

PIN	A1	A2	A3	A4	A5	A6	A7	AB	AB	A9	A10	A11	A12
GND	TX1+	TX1-	VBUS	CC1	D+	D-	SBU1	VBUS	RX2-	RX2+	GND		
GND	RX1+	RX1-	VBUS	SBU2	D-	D+	CC2	VBUS	TX2-	TX2+	GND		
	B12	B11	B10	B9	B8	B7	B6	B5	B4	B3	B2		

- Environmental Characteristics
  - Salt Spray: 4BH
  - IR Reflow: Peak Temperature 245±5°C (Time:30S)
  - Operating Temperature Range: -30°C to +85°C.
  - Storage Temperature Range: -20°C to +60°C.
  - Relative Humidity: 15~70%RH
  - Storage Life : 6 Months
- Comply to Rohs2.0 & HF.

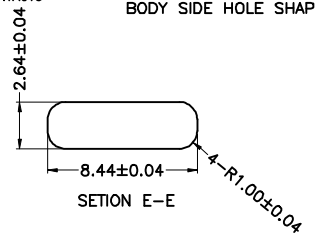
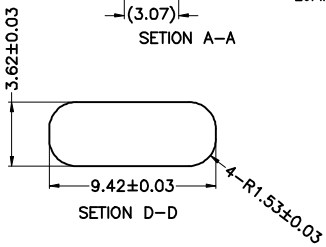
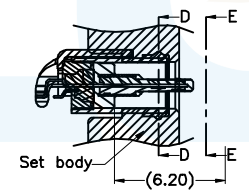
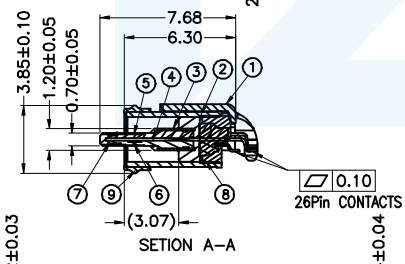
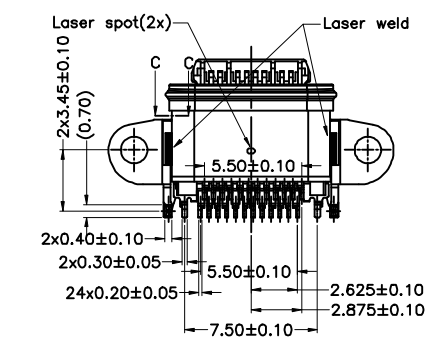
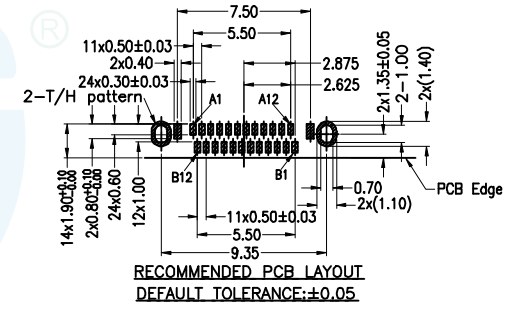
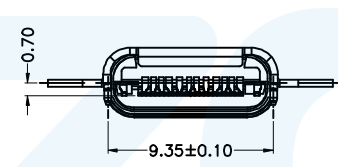
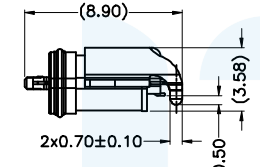
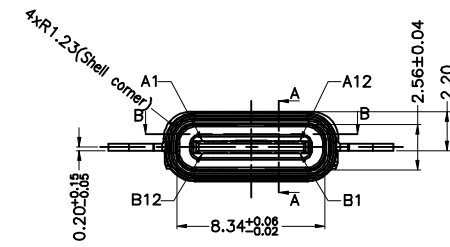
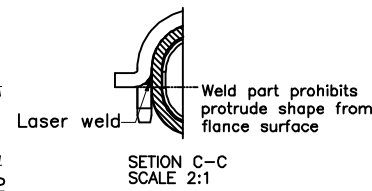
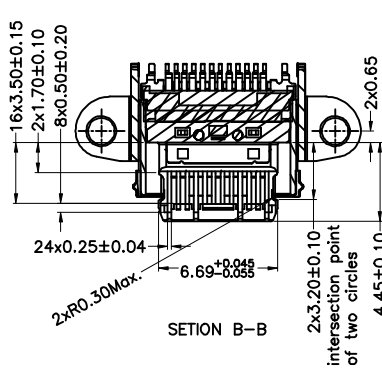
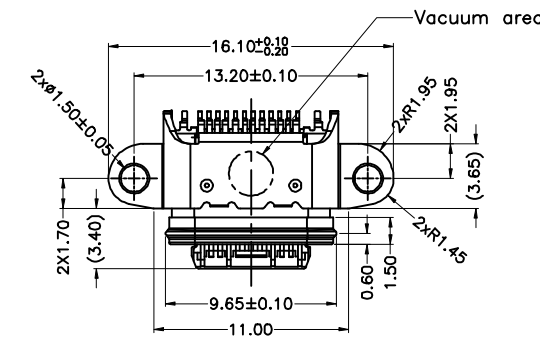

NO.	DESCRIPTION	MATERIAL	REMARKS	QTY
9	Liquid Rubber	SILICONE	Color:Black	1
8	Rubber	SILICONE	Color:Black	1
7	Insertmolding	LCP E680B	Color:Black UL94 V-0	1
6	Bottom Contact	C18150-R540, T=0.12	Mating Area: Ni 50u"MIN.+Au 15u" Min.	12
5	Top Contact	C18150-R540, T=0.12	Solder Tails: Ni 50u"MIN.+Au 1u" Min.	12
4	Mid Plate	SUS301R-H, T=0.15	Ni 50u"Min.+Solder area: Au 1u"Min.	1
3	GND Plate	SUS301R-H, T=0.10	None	2
2	Shell	SUS316, T=0.30	Ni 50u" MIN. UNDER PLATED OVER ALL.	1
1	Frame	SUS304R-1/2H, T=0.30	Ni 50u" MIN. UNDER PLATED OVER ALL.	1

**LZG** LZG INDUSTRIAL CO. LTD

DRAWING:	林生财	DATE:	2020.02.18	SCALE	1:1
CHECK:	李宏鑫	DATE:	2020.02.18	MATERIAL	*
APPROVAL:	杨进宝	DATE:	2020.02.18	DWG. NO.	
DRAWING NO.	ZB48065-24SBAP-A			SHEET	1/1

PART NAME	WATERPROOF TYPE C 24 PIN	TOLERANCE UNLESS	0.0±0.3	0.°±2°	UNIT:	
PART NO.	ZB48065-24SBAP-A	OTHERWISE SPECIFIED:	0.00±0.2	0.0°±1°	mm	
			0.000±0.1	0.00°±0.5°		