

RoHS
Compliant

ZONE	E C N . N O .	DESCRIPTION	DRAWING	DATE
A		INITIAL	林生財	2023.11.20

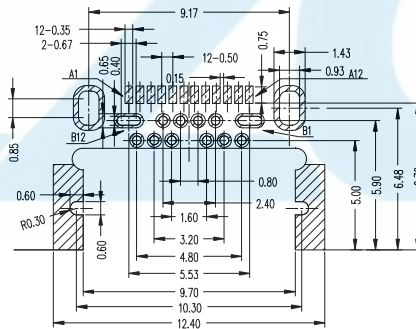
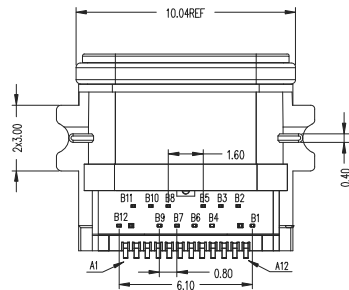
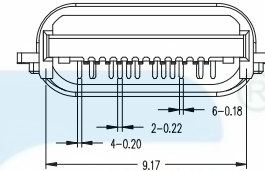
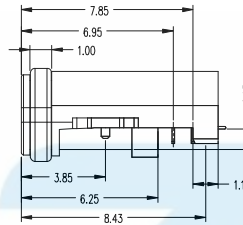
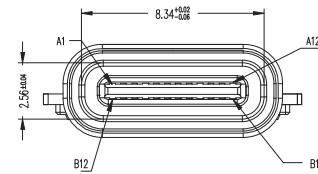
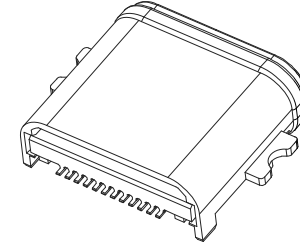
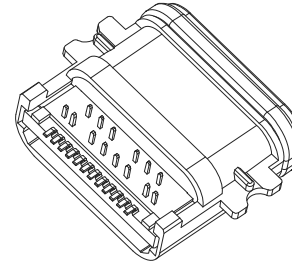
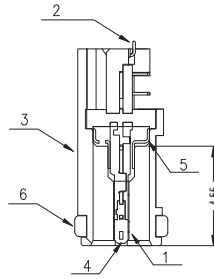
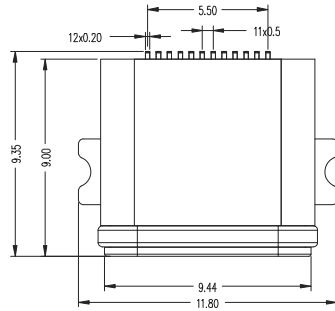

TABLE B

A1	GND	B12	GND
A2	SSTXP1	B11	SSRX1
A3	SSTXN1	B10	SSRXN1
A4	VBUS	B9	VBUS
A5	CC1	B8	SBUS2
A6	DP1	B7	DN2
A7	DN1	B6	DP2
A8	SBUS1	B5	CC2
A9	VBUS	B4	VBUS
A10	SSRXN2	B3	SSTXN2
A11	SSRX2	B2	SSTX2
A12	GND	B1	GND
PIN	SIGNAL NAME	PIN	SIGNAL NAME

TABLE A

6	RING	SILICON	---	1PCS	
5	MID-PLANT	STAINLESS STEEL	---	1PCS	
4	GND-PLANT	STAINLESS STEEL	Ni/SN Plated	1PCS	
3	SHELL	ZN-ALLOY	---	1PCS	
2	CONTACT	COPPER ALLOY	Au/Ni Plated	2SET	
1	HOUSING	HIGH TEMPERATURE PLASTIC	BLACK	1PCS	
NO.	DESCRIPTION	MATERIAL	FINISH PLANTED	QTY	REMARKS

RECOMMEND PCB LAYOUT
TOL=±0.05

SPECIFICATION:

1.ELECTRICAL:

1-1:CURRENT RATING:

VBUS AND GND CONTACTS RATED AT 1.25A
PARALLELED FOR A TOTAL OF 5A;

1-2:INITIAL CONTACT RESISTANCE :40 MEGOHMS

1-3:DIELECTRIC WITHSTANDING VOLTAGE:100V AC MIN;

2:MECHANICAL CHARACTERISTICS:

2-1:MATING FORCE:5~20N

2-2:UNMATING FORCE:8~20N(INITIAL),6~20N(AFTER 10000 CYCLES)

2-3:FREQUENCY:200±50 CYCLES/HOUR,10000 CYCLES

2-4:OPERATING TEMPERATURE:~40~80°

3:WATERPROOF: IP67.



LZG INDUSTRIAL CO. LTD

DRAWING:	林生財	DATE:	2023.11.20	SCALE	1:1
CHECK:	李宏鑫	DATE:	2023.11.20	MATERIAL	*
APPROVAL:	徐進堂	DATE:	2023.11.20	DWG. NO.	
DRAWING NO.	ZB48033-24FBAP-A			SHEET	1/1

PART NAME	USB 3.1 TYPE-C 端子連接器殼 沉板(1.0)鍍鍍層	TOLERANCE UNLESS	0.0±0.25	0.1±0.2*	UNIT: mm
PART NO.	ZB48033-24FBAP-A	OTHERWISE SPECIFIED:	0.00±0.15 0.000±0.10	0.0±0.1* 0.00±0.5*	