

RoHS
Compliant

ZONE	E C N . N O .	DESCRIPTION	DRAWING	DATE
A		INITIAL	林生财	2023.11.24

MATCHED MECHANISM'S ID NEED TO
AVOID INTERFERENCE WITH TERMINAL
AFTER PLUG IN

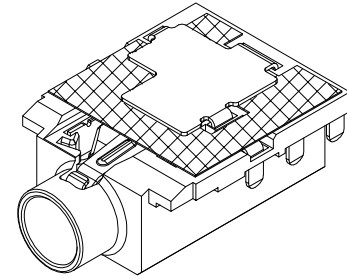
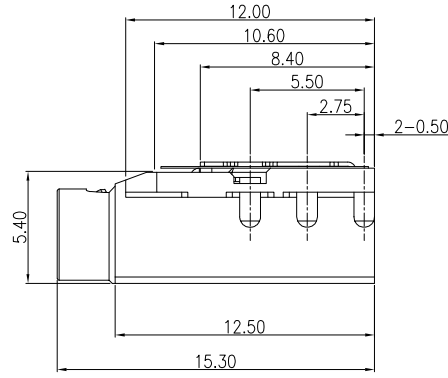
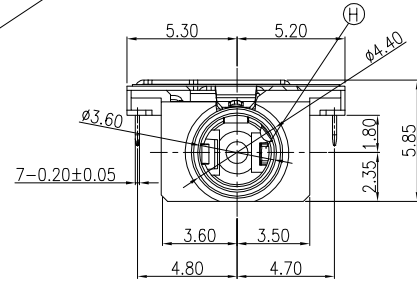
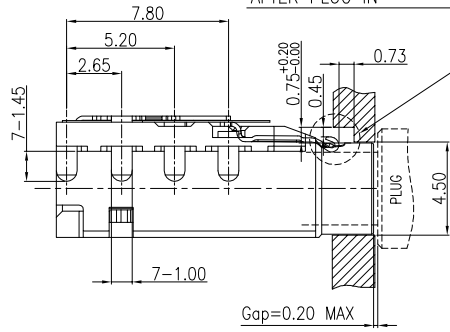

3D VIEW

NOTES:

- MATERIAL: SEE "TABLE 1";
- FINISH: SEE "TABLE 1";
- ELECTRICAL:
 - VOLTAGE RATING: 12 VAC RMS;
 - CURRENT RATING: 0.5 AMP;
 - CONTACT RESISTANCE: 50mΩ Max.(Initial), 100mΩ Max.(After Life test);
 - INSULATION RESISTANCE: 1000 MΩ Min., 500VDC.(Initial), 100 MΩ Min., 500VDC.(After Humidity test);
 - WITHSTAND VOLTAGE: 500 VAC RMS 50(60)Hz, 1 minute;
- MECHANICAL:
 - MATING FORCE: 3.0Kgf MAX.;
 - UNMATING FORCE: 0.3Kgf MIN.;
 - OPERATING LIFE: 5000 CYCLES MIN.;
- ENVIRONMENTAL:
 - OPERATION: -30°C~+80°C.

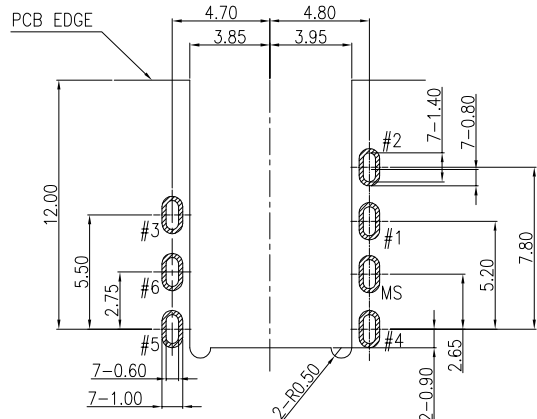

RECOMMENDED P.C.B LAYOUT
TOP VIEW (TOLRANCE:±0.05)

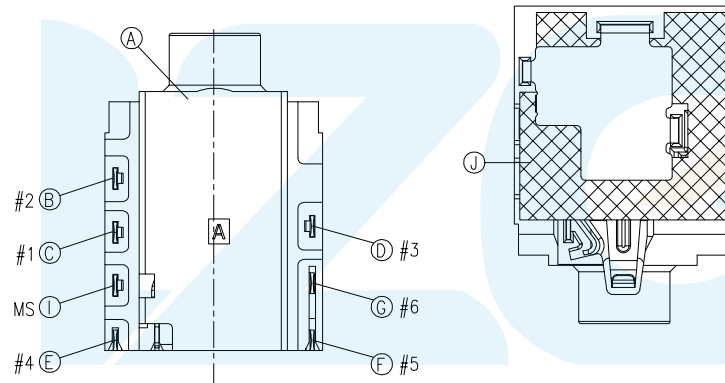
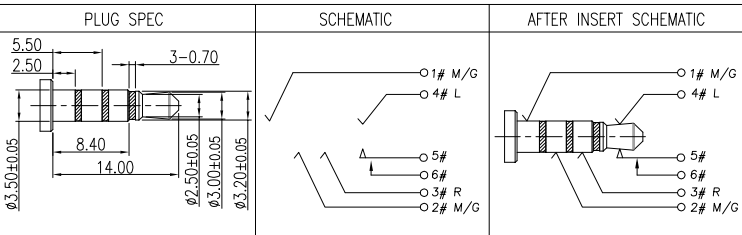

TABLE 1:

NO.	PART NAME	QTY	MATERIAL	DESCRIPTION	REMARK
Ⓚ	MYLAR	1	KAPTON	YELLOW	T=0.08mm
Ⓛ	SHELL	1	C2680-H	Ni 50 u" Min.	T=0.20mm
Ⓜ	SEPARATOR	1	LCP	BLACK	UL94V-0
Ⓝ	MAKE TERNINAL	1	C5210-H	CONTACT AREA: GF SOLDER AREA: GF, Ni 50u" OVER ALL	T=0.20mm
Ⓧ	TRANSFER TERMINAL	1	C5210-H		T=0.20mm
Ⓨ	TIP SPRING	1	C5210-H		T=0.20mm
Ⓩ	RING A	1	C5210-H	CONTACT AREA: GF SOLDER AREA: MATTE TIN 80u" Min. Ni 50u" OVER ALL	T=0.20mm
Ⓛ	EARTH	1	C5210-H		T=0.20mm
Ⓜ	RING B	1	C5210-H		T=0.20mm
Ⓜ	BODY	1	PA10T	BLACK	UL94V-0



LZG INDUSTRIAL CO. LTD

DRAWING:	林生财	DATE:	2023.11.24	SCALE	1:1
CHECK:	李宏鑫	DATE:	2023.11.24	MATERIAL	*
APPROVAL:	杨进宝	DATE:	2023.11.24	DWG. NO.	
DRAWING NO.	ZB23025-07FBAP-A			SHEET	1/2

PART NAME	Ø3.50mm PHONE JACK	TOLERANCE UNLESS	0.0±0.25	0.°±2°	UNIT: mm
PART NO.	ZB23025-07FBAP-A	OTHERWISE SPECIFIED:	0.00±0.15 0.000±0.05	0.0°±1° 0.00°±0.5°	

RoHS
Compliant

ZONE	E C N . N O .	DESCRIPTION	DRAWING	DATE
A		INITIAL	林生财	2023.11.24

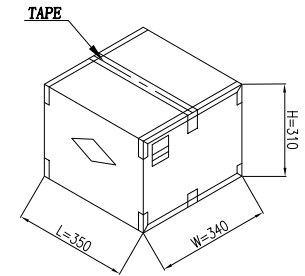
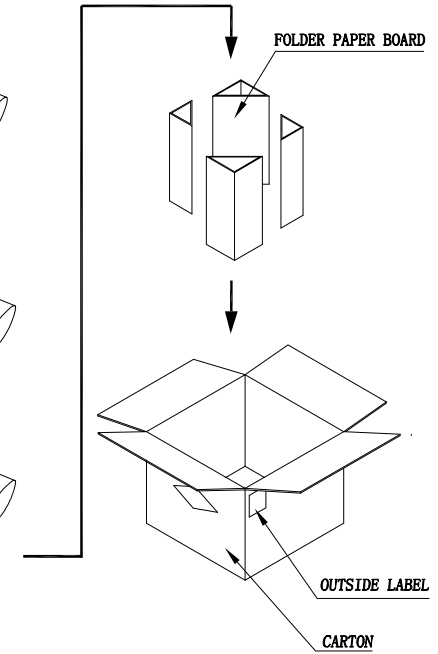
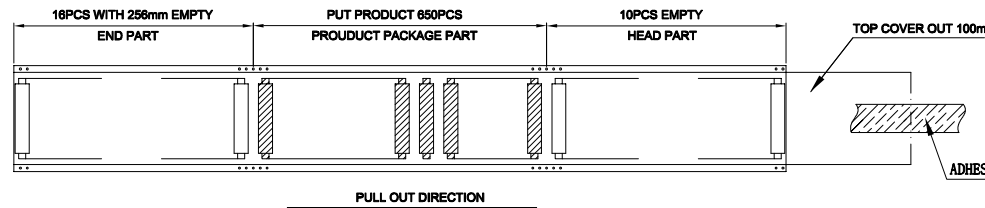
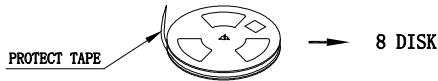
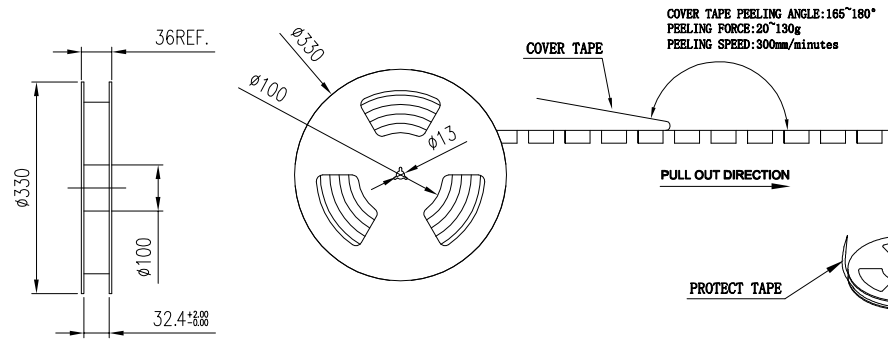

1 CARTON = 8 REEL = 5200 PRODUCT

NOTES:

- Material requirements:
 - The carton material requirements for the K-A, Dimension is 350*340*310mm;
 - Reel materials for PS; size reel for 330*36.
- Packaging requirements:
 - The tape into the packing machine, before the empty 10PCS, after the release of the product 650PCS, then the empty 16PCS with 256mm length of stay;
 - Top cover should out 100mm of the carrier tape. After winding, using adhesive tape (80-150mm) to stick the leader of cover tap on the side of the carrier tape;
 - Winding a protect tape around the reel, then stick it by adhesive tape;
 - Label should paste in the designated area of the reel;
 - Put a dryer and a packed reel in the vacuum bag and make the vacuum process;
 - The tired folded 8 disks in the carton total 5200pcs;
 - Packed finished packing sealing, and in the outer carton label

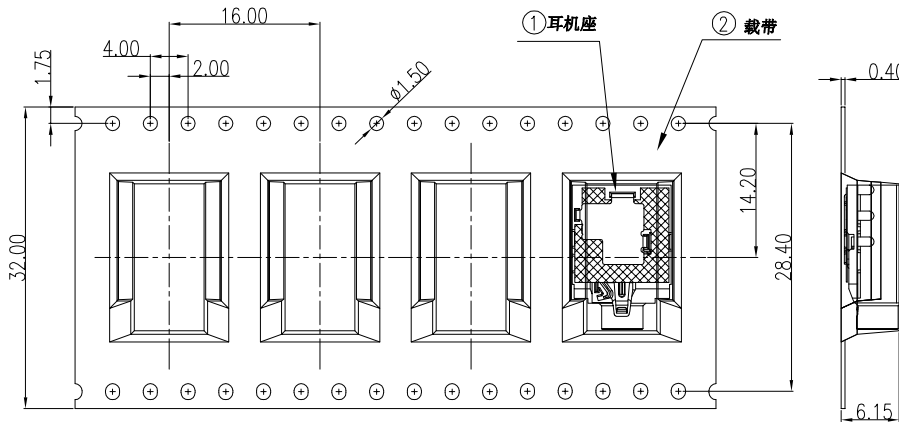

LZG INDUSTRIAL CO. LTD

PART NAME	ø3.50mm PHONE JACK	TOLERANCE UNLESS	0.0±0.25	0.°±2°	UNIT: mm	APPROVAL:	杨进宝	DATE:	2023.11.24	DWG. NO.	ZB23025-07FBAP-A
PART NO.	ZB23025-07FBAP-A	OTHERWISE SPECIFIED:	0.00±0.15 0.000±0.05	0.0°±1° 0.00°±0.5°							

DRAWING:	林生财	DATE:	2023.11.24	SCALE	1:1
CHECK:	李宏鑫	DATE:	2023.11.24	MATERIAL	*
DRAWING NO.	ZB23025-07FBAP-A	SHEET	2/2		