

**RoHS**  
Compliant

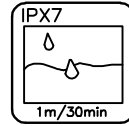

ZONE	EC N . N O .	DESCRIPTION	DRAWING	DATE
A		INITIAL	林生财	2020.02.18

- SPECIFICATIONS:**
- RATING: 12V, 1A .
  - CONTACT RESISTANCE: 30mΩ OR LESS FOR INITIAL
  - VOLTAGE PROOF: 500V AC FOR ONE MINUTE
  - DURABILITY: 5,000 INSERTION/EXTRACTION CYCLES
  - INSERTION FORCE: 3.0KG MAX
  - WITHDRAWAL FORCE: 0.3KG MIN
  - WATER PROOFNESS: THIS PRODUCT IS BASED ON IPX7(1m,30min)
  - USING PLUG: Ø3.5MM, 3-POLE STEREO
  - OVAL RING
  - 9-1. Hardness of silicone rubber: 70°
  - 9-2. Horizontal flash 0.10mm max; Longitudinal flash 0.10mm max
  - HOUSING WITH O-RING'S SEAL AREA BURRS IS 0.05mm MAX.
  - FOR REFLOW SOLDERING LEAD-FREE PROCESS.
  - PACKAGING: TAPE & REEL.

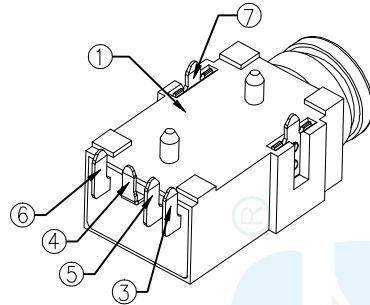
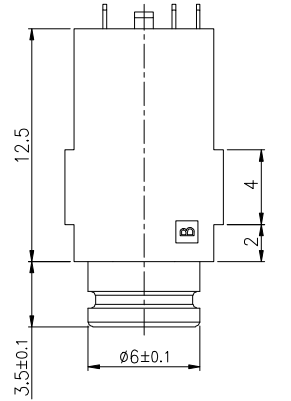
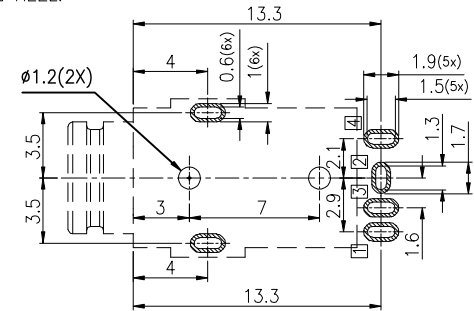
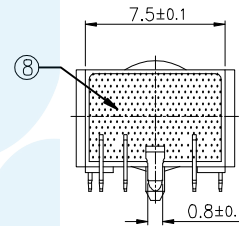
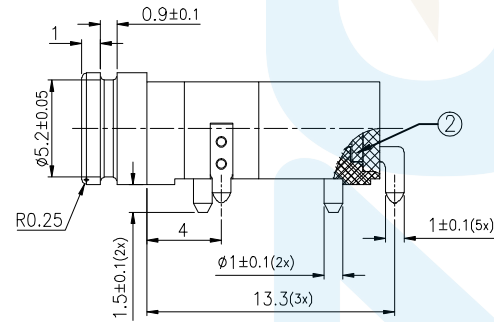
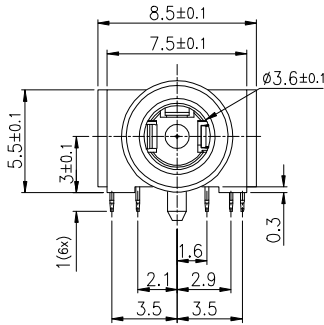

Recommended PCB Layout(T=1.2)  
Tolerance: ±0.05(TOP view)

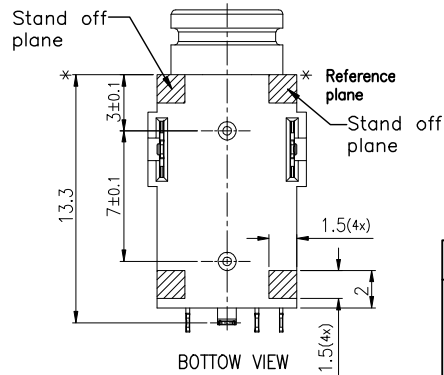

□ : TERMINAL NO.

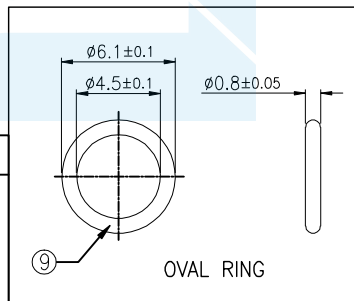
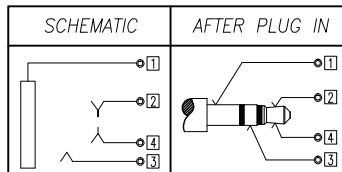

9	OVAL RING	SILICONE	COLOR GREEN	1
8	BOND	EPOXY	----	1
7	TERMINAL	C2680R-H T=0.2	Matte Sn 80u" Min; Ni 40u" Min underplate	2
6	TIP SPRING-2	C5210R-EH T=0.2	Matte Sn 80u" Min; Ni 40u" Min underplate	1
5	RING SPRING	C5210R-EH T=0.2	Matte Sn 80u" Min; Ni 40u" Min underplate	1
4	TIP SPRING-1	C5210R-EH T=0.2	Matte Sn 80u" Min; Ni 40u" Min underplate	1
3	EARTH SPRING	C5210R-EH T=0.2	Matte Sn 80u" Min; Ni 40u" Min underplate	1
2	COVER	PA9T 94V-0	COLOR BLACK	1
1	HOUSING	PA9T 94V-0	COLOR BLACK	1
NO.	DESCRIPTION	MATERIAL	REMARKS	QTY

**LZG**

LZG INDUSTRIAL CO. LTD

DRAWING:	林生财	DATE:	2020.02.18	SCALE	1:1
CHECK:	李宏鑫	DATE:	2020.02.18	MATERIAL	*
APPROVAL:	杨进宝	DATE:	2020.02.18	DWG. NO.	
DRAWING NO.	ZB23008-06SBAP-A			SHEET	1/1

PART NAME	WATERPROOF Ø3.5 PHONE JACK	TOLERANCE UNLESS	0.0±0.30	0.°±2'	UNIT:
PART NO.	ZB23008-06SBAP-A	OTHERWISE SPECIFIED:	0.00±0.20 0.000±0.10	0.0°±1' 0.00°±0.5'	