

RoHS  
Compliant

ZONE	E.C.N.O.	DESCRIPTION	DRAWING	DATE
A		INITIAL	林生财	2020.02.18
Rating	DC30V 100mA	Electrical Life	1,0000 cycles	
Contact Resistance	100mΩ Max	Mechanical Life	1,0000 cycles	
Insulation Resistance	>100MΩ DC500V	Ambient Temper. Used	-25℃ to +85℃	
Withstand Voltage	AC250V 1min.	Ambient Humidity Used	≤85% at +40℃	
Soldering Temper.	235±5℃ 5s	Operating Force	30±20gf max	

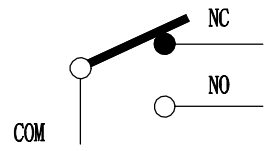
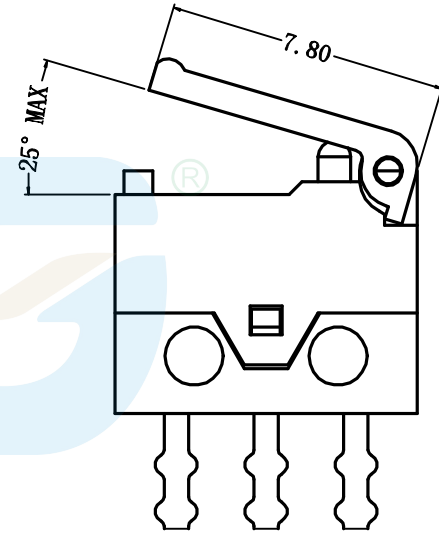
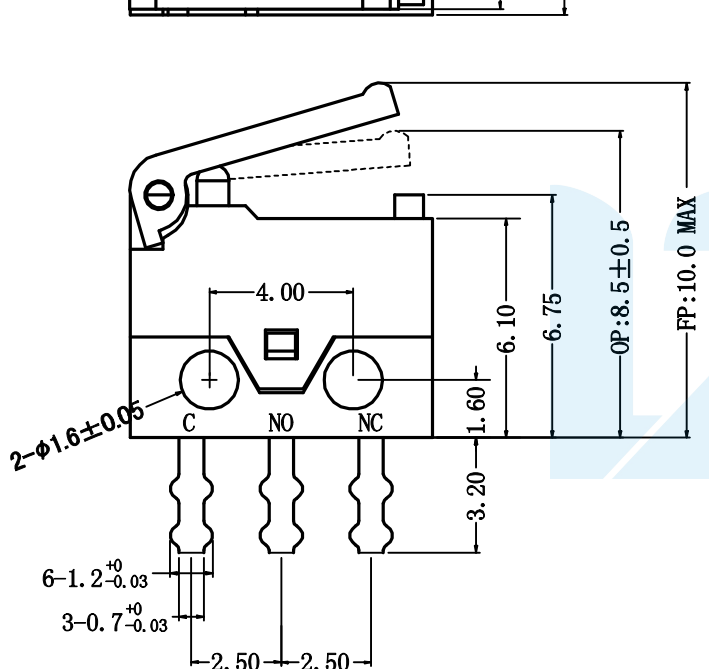
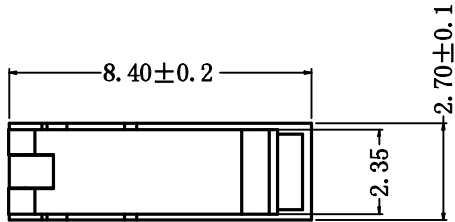

7	压柄 (LEVER)	1	尼龙 (Nylon)	
6	端子 (TERMINAL)	3	C2680 (Brass)	镀银 (Silver plating)
5	触点 (CONTACT)	1	银合金 (Silver Alloy)	
4	按钮 (BUTTON)	1	PBT	
3	弹片 (SPRING)	1	C17200 (Beryllium copper)	
2	盖片 (COVER)	1	尼龙 (Nylon)	
1	底座 (BASE)	1	尼龙 (Nylon)	黑色 (Black)
序号 NO.	零件名称 Part Name	数量 Quantity	材质 Material	备注 Notes

**LZG** LZG INDUSTRIAL CO. LTD

PART NAME	超小型微动开关 (2.7井深)	TOLERANCE UNLESS	10<L<20 ±0.20	0.°±2°	UNIT:
PART NO.	DS027-01P-30-3	OTHERWISE SPECIFIED:	6<L<10 ±0.15	0.0°±1°	
			1<L<6 ±0.10	0.00°±0.5°	
			L<1 ±0.05		

DRAWING:	林生财	DATE:	2020.02.18	SCALE	1:1
CHECK:	李宏鑫	DATE:	2020.02.18	MATERIAL	*
APPROVAL:	杨进宝	DATE:	2020.02.18	DWG. NO.	
DRAWING NO.	DS027-01P-30-3			SHEET	1/1