

RoHS
Compliant

ZONE	E.C.N.O.	DESCRIPTION	DRAWING	DATE
A		INITIAL	林志財	2023.12.22

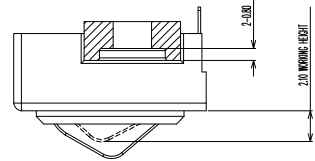
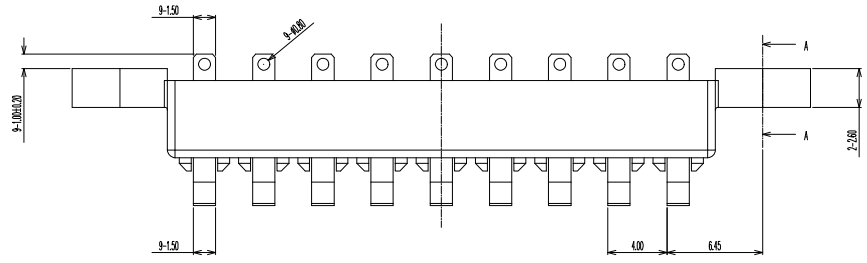

SECTION A-A

← INSERT THE ONLY DIRECTION OF THE BATTERY

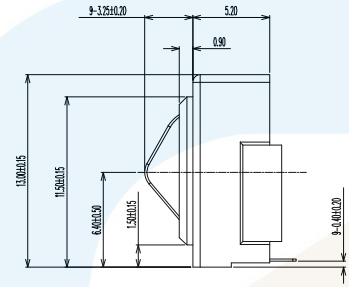
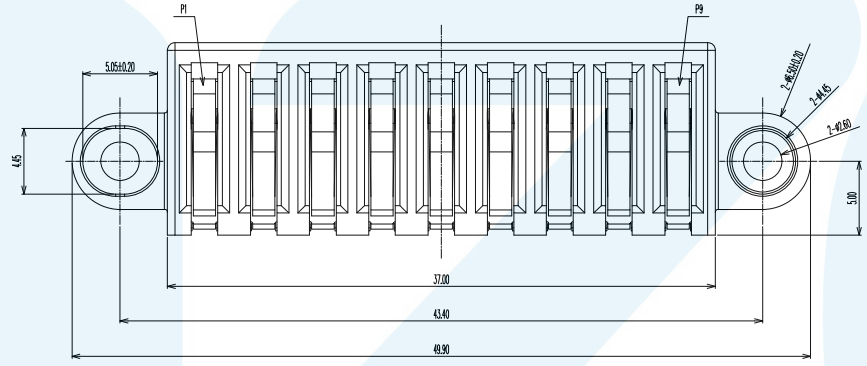

- SPECIFICATIONS:**
- ELECTRICAL CHARACTERISTICS:**
 - CURRENT RATING: 2A
 - RATING VOLTAGE: 12V DC
 - CONTACT RESISTANCE: 30mΩ Max.(INITIAL), 50mΩ Max.(AFTER LIFE)
 - DIELECTRIC WITHSTANDING VOLTAGE: 500V AC FOR ONE MINUTE.
 - INSULATION RESISTANCE: 100MΩ MIN. BY 500V DC.
 - MECHANICAL CHARACTERISTICS:**
 - TERMINAL FORCE: 0.65±0.2N AT 1.2mm STROKE PER TERMINAL.
 - LIFE TEST: 10,000 CYCLES MIN.
 - ENVIRONMENTAL CHARACTERISTICS:**
 - SALT MIST TEST CONDITION: PER IEC 68-2-52, SEVERITY(3)
 - OPERATING TEMPERATURE: -30°~+80°
 - RoHS COMPLIANT PRODUCT.
 - HALOGEN FREE PRODUCT IDENTIFICATION MARK:
 - HALOGEN FREE PRODUCT IDENTIFICATION LABEL ON PACKAGING:
 - OTHER GENERAL SPEC. TO REFER "9A2035 SERIES SPEC."
 - FOR REFLOW SOLDERING LEAD-FREE PROCESS.
 - PACKAGING: TAPE & REEL.

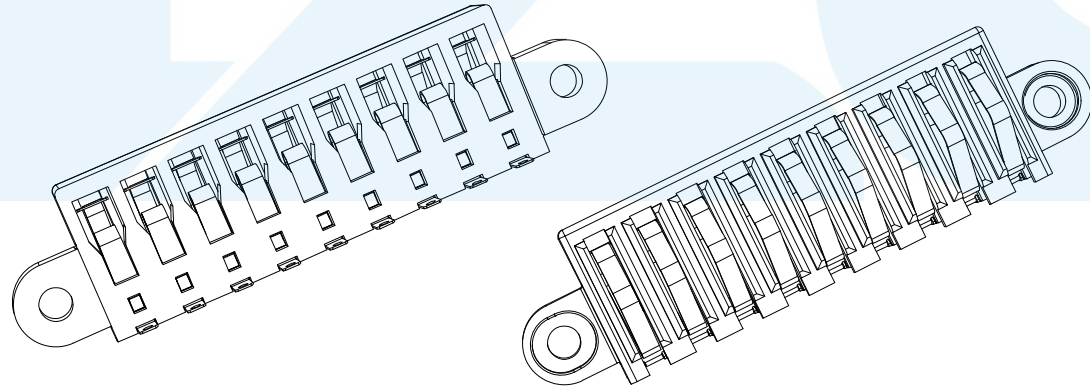

NO.	DESCRIPTION	QTY	MATERIAL	PLATING & COLOR
A	HOUSING	1	PA 101+300FJUM-10	BLACK
B	TERMINAL	9	C035 T=0.15	Au 24" ON CONTACT AREA;F ON SOLDER AREA; 60" MIN ALL

LZG® LZG INDUSTRIAL CO. LTD

PART NAME	9PIN BATTERY CONNECTOR	TOLERANCE UNLESS	0.0±0.25	0.1±2°	UNIT:	
PART NO.	D-BATT3713-9P	OTHERWISE SPECIFIED:	0.00±0.15 0.000±0.05	0.0°±1° 0.00°±0.5°	mm	

DRAWING:	林志財	DATE:	2023.12.22	SCALE	1:1
CHECK:	李宏鑫	DATE:	2023.12.22	MATERIAL	*
APPROVAL:	楊建堂	DATE:	2023.12.22	DWG. NO.	
DRAWING NO.			D-BATT3713-9P	SHEET	1/1

F E D C B A