

RoHS
Compliant

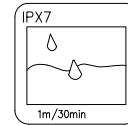

ZONE	ECN.N.O.	DESCRIPTION	DRAWING	DATE
A		INITIAL	林生財	2023.10.26

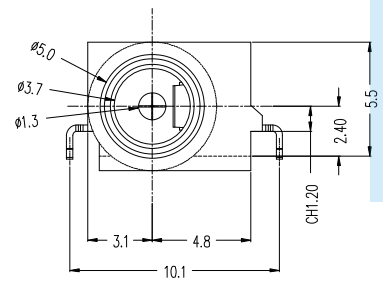
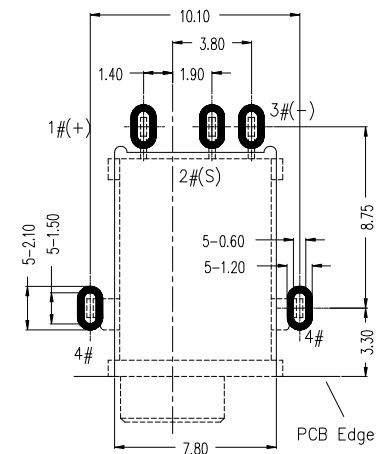
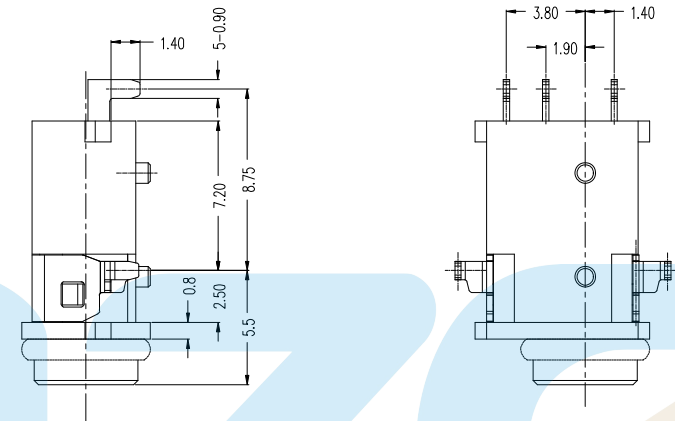
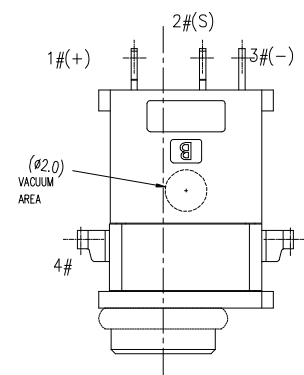
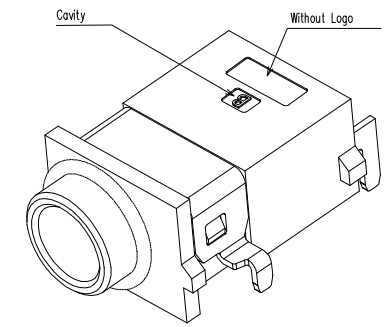
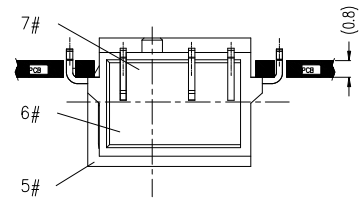

- NOTES
- CURRENT RATING: 24V & 1.5A MAX.
 - CONTACT RESISTANCE: 50mΩ MAX.
 - INSULATION RESISTANCE: 100MΩ MIN.
 - DIELECTRIC WITHSTANDING: 500V AC MIN.
 - DURABILITY: 5000 CYCLES MIN.
 - CONNECTOR MATING FORCES: 3N MIN.
 - CONNECTOR UNMATING FORCES: 35N MAX.
 - OPERATING TEMPERATURE: -25°C TO +85°C.

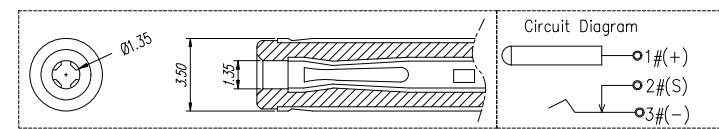

8	WATERPROOF RING	1	SILICONE; WHITE
7	GLUE	1	EPOXY; BLACK
6	BACK COVER	1	HIGH TEMPERATURE; BLACK
5	HOUSING	1	HIGH TEMPERATURE; BLACK
4	TERMINAL 4#	1	STAINLESS STEEL; NICKEL PLATING
3	TERMINAL 3#	1	COPPER ALLOY; NICKEL UNDERPLATING OVERALL, Au PLATING ON THE SOLDER AREA
2	TERMINAL 2#	1	COPPER ALLOY; NICKEL UNDERPLATING OVERALL, Au PLATING ON THE WHOLE
1	CENTER PIN	1	COPPER ALLOY; NICKEL UNDERPLATING OVERALL, Au PLATING ON THE SOLDER AREA
ITEM	NAME	QTY	DESCRIPTION

Not to install the waterproof ring shipment

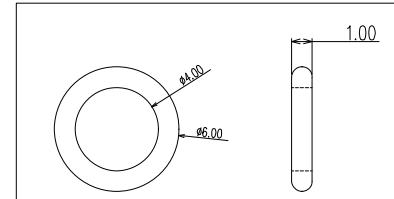

LZG® LZG INDUSTRIAL CO. LTD

PART NAME	Ø1.3 DC WATERPROOF POWER JACK	TOLERANCE UNLESS	0.0±0.25	0.1±2°	UNIT: mm
PART NO.	ZB30010-05FBAP-A	OTHERWISE SPECIFIED:	0.00±0.15	0.0°±1'	
			0.000±0.10	0.00°±0.5'	

DRAWING:	林生財	DATE:	2023.10.26	SCALE	1:1
CHECK:	李致鑫	DATE:	2023.10.26	MATERIAL	*
APPROVAL:	楊建堂	DATE:	2023.10.26	DWG. NO.	
DRAWING NO.	ZB30010-05FBAP-A			SHEET	1/1