

3D VIEW

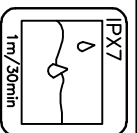

ZONE	ECN .NO.	DESCRIPTION	DRAWING	DATE
A		INITIAL	林生财	2020.02.18

- NOTES:
SPECIFICATION:
- CURRENT RATING: 3.0A MAX
 - DIELECTRIC WITHSTAND VOLTAGE: 100VAC
 - TEMPERATURE RANGE: -30 °C ~ 85 °C
 - CONTACT RESISTANCE: 40 MILLIONHM MAX
 - INSULATION RESISTANCE: 100 MEGOHMS MIN.
 - INSERTION FORCE :10N~30N
 - UNMATING FORCE: 8N~30N
 - DURABILITY:1500 CYCLES

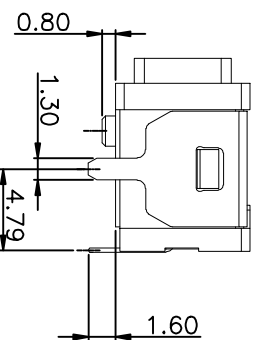
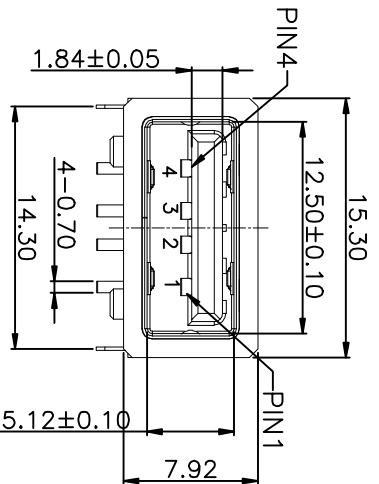
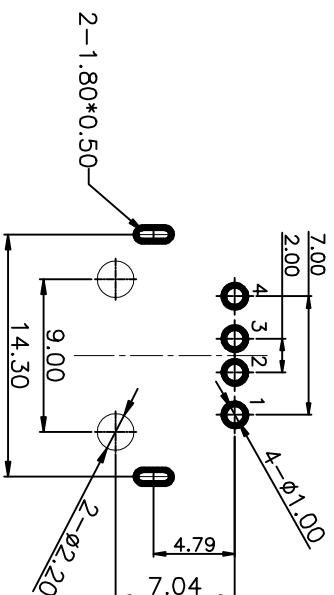

RECOMMENDED PCB LAYOUT(TOP VIEW)
THICKNESS T=1.0mm
DEFAULT TOLERANCE+/-0.05

PIN ASSIGNMENT

PIN NO.	1	2	3	4
SIGNAL NAME	VBUS	D-	D+	GND

结构设计注意:
1. 成品使用时, 如有洗面奶泡沫、牙膏、洗手液、脏污液体, 请在 TYPE-C口外面再设计一层外壳, 保护 TYPE-C表面金手指不会被脏污覆盖。

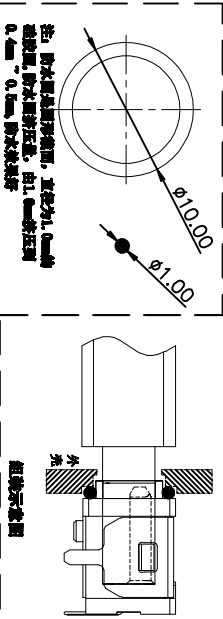

NO.	DESCRIPTION	MATERIAL	REMARKS	QTY
1	HOUSING	PA10T	COLOR BLACK	1
2	CONTACT	BRASS	Au/Ni Plating T=0.25mm	4
3	PLASTIC SHELL	PA10T	COLOR BLACK	1
4	INNER SHELL	SUS 301	WASH	1
5	OUTER SHELL	SUS 301	WASH	1

DRAWING:	DATE:	SCALE	1/1
林生财	2020.02.18		
CHECK:	DATE:	MATERIAL	*
李洪鑫	2020.02.18		
APPROVAL:	DATE:	DWG. NO.	
杨进宝	2020.02.18		
DRAWING NO.	ZB40002-06DBAP-A	SHEET	1/1

LZG INDUSTRIAL CO. LTD

PART NAME	WATERPROOF USB 2.0 A TYPE	TOLERANCE	UNLESS	0.0±0.3	0.0±0.1	0.1±2°	0.0°±1'	UNIT:	mm	APPROVAL:	杨进宝	DATE:	2020.02.18	DWG. NO.	
PART NO.	ZB40002-06DBAP-A	OTHERWISE	SPECIFIED:	0.000±0.05	0.00±0.5	0.00±0.5'									