

RoHS Compliant

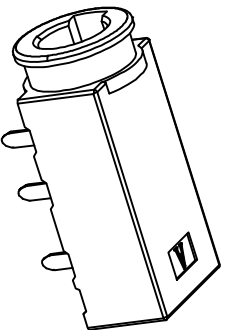

3D VIEW

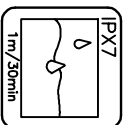

ZONE	E	C	N	O
A				

DESCRIPTION

DRAWING

DATE

2020.02.18

NOTES

- CURRENT RATING: 1A.
- CONTACT RESISTANCE: 100mΩ MAX.
- INSULATION RESISTANCE: 100MΩ MIN.
- DIELECTRIC WITHSTANDING: 500V AC MIN.
- DURABILITY: 5000 CYCLES MIN.
- CONNECTOR MATING FORCES: 3~30N.
- CONNECTOR UNMATING FORCES: 3~30NX.
- SALT SPRAY: 24HOUR
- WATERPROOF LEVEL: IP67.
- OPERATING TEMPERATURE: -25°C TO +85°C.

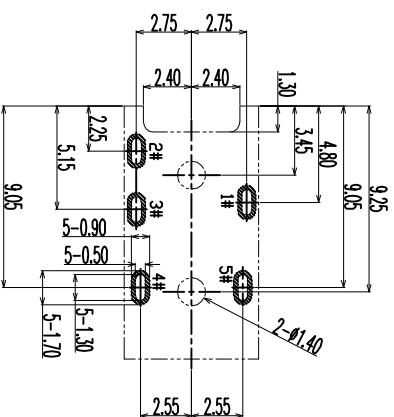
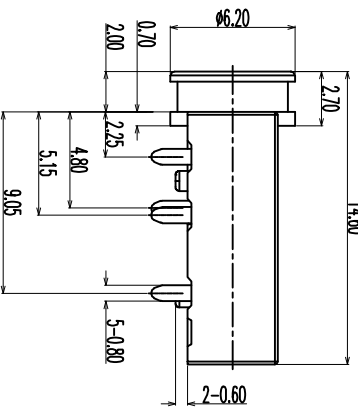
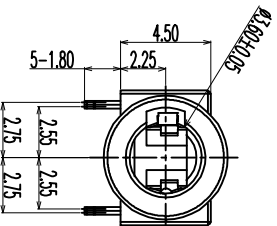

PCB LAYOUT (TOP VIEW)
TOLERANCE: ±0.05

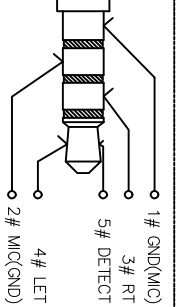
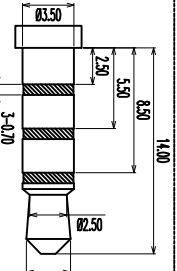
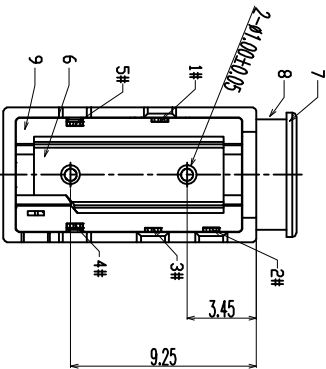

SCHEMATIC

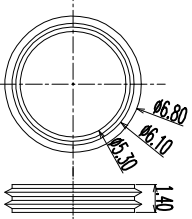

BLACK WATERPROOF RINGS

NO.	DESCRIPTION	MATERIAL	REMARKS	QTY
9	GLUE	EPOXY	COLOR BLACK	1
8	WATERPROOF RING	SILICONE	COLOR BLACK	1
7	HOUSING	HIGH TEMPERATURE	COLOR BLACK	1
6	COVER	STAINLESS STEEL	COLOR BLACK	1
5	TERMINAL 5#	STAINLESS STEEL	NICKEL UNDERPLATING OVERALL, GOLD FLASH PLATING ON THE SOLDER & CONTACT AREA	1
4	TERMINAL 4#	STAINLESS STEEL	NICKEL UNDERPLATING OVERALL, GOLD FLASH PLATING ON THE SOLDER & CONTACT AREA	1
3	TERMINAL 3#	PHOSPHOR BRONZE	NICKEL UNDERPLATING OVERALL, GOLD FLASH PLATING ON THE SOLDER & CONTACT AREA	1
2	TERMINAL 2#	PHOSPHOR BRONZE	NICKEL UNDERPLATING OVERALL, GOLD FLASH PLATING ON THE SOLDER & CONTACT AREA	1
1	TERMINAL 1#	STAINLESS STEEL	NICKEL UNDERPLATING OVERALL, GOLD FLASH PLATING ON THE SOLDER & CONTACT AREA	1

Not to install the waterproof ring shipment

LZG INDUSTRIAL CO., LTD

PART NAME WATERPROOF Ø3.5 PHONE JACK
PART NO. ZB23017-05DBAP-A

TOLERANCE UNLESS OTHERWISE SPECIFIED: 0.000±0.10

UNIT: mm

CHECK: 李宏鑫

DATE: 2020.02.18

DATE: 2020.02.18

DATE: 2020.02.18

DATE: 2020.02.18

DATE: 2020.02.18

F

E

D

C

B

A