

- SPECIFICATIONS:
- 1.RATING: 12V, 1A.
 - 2.CONTACT RESISTANCE:30mΩ OR LESS FOR INITIAL
 - 3.VOLTAGE PROOF:500V AC FOR ONE MINUTE
 - 4.DURABILITY:5,000 INSERTION/EXTRACTION CYCLES
 - 5.INSERTION FORCE:3.0KG MAX
 - 6.WITHDRAWAL FORCE:0.3KG MIN
 - 7.WATER PROOFNESS: THIS PRODUCT IS BASED ON IPX7(1m,30min)
 - 8.USING PLUG: Φ3.5MM、3-POLE STEREO
 9. OVAL RING
 - 9-1. Hardness of silicone rubber: 70°
 - 9-2. Horizontal flash 0.10mm max; Longitudinal flash 0.10mm max
 - 10.HOUSING WITH O-RING'S SEAL AREA BURS IS 0.05mm MAX.
 - 11.FOR REFLOW SOLDERING LEAD-FREE PROCESS.
 - 12.PACKAGING: TAPE & REEL.

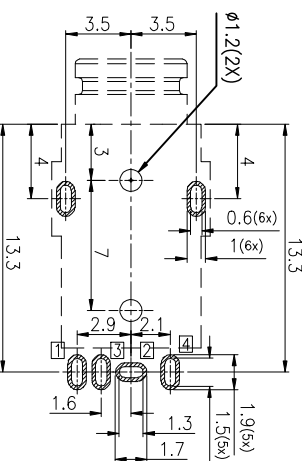

Recommended PCB layout(T=1.2)
Tolerance: ±0.05(TOP view)

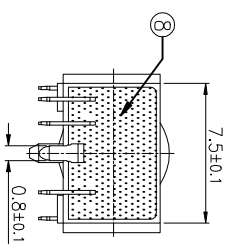
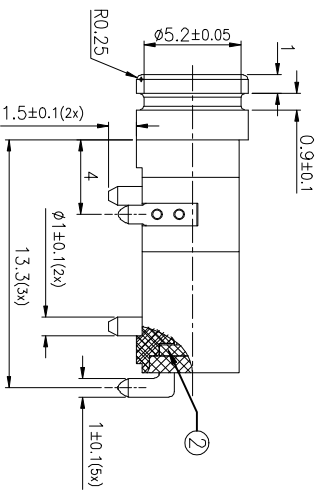
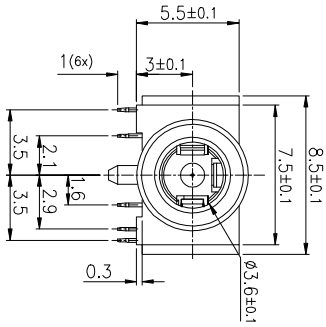
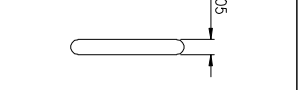
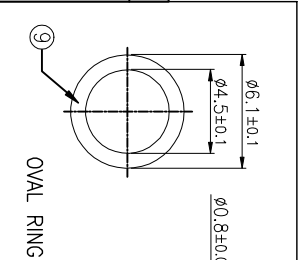
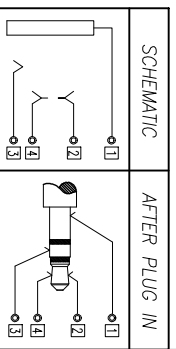
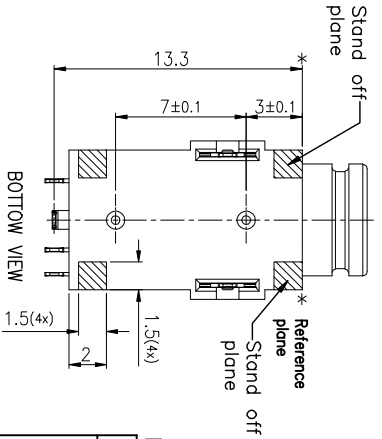

NO.	DESCRIPTION	MATERIAL	COLOR	REMARKS	QTY
9	OVAL RING	SILICONE	COLOR GREEN		1
8	BOND	EPOXY	---		1
7	TERMINAL	C2690R-H T=0.2	Matte Sn 80u" Min; Ni 40u" Min underplate		2
6	TP SPRING-2	CS210R-EH T=0.2	Matte Sn 80u" Min; Ni 40u" Min underplate		1
5	RING SPRING	CS210R-EH T=0.2	Matte Sn 80u" Min; Ni 40u" Min underplate		1
4	TP SPRING-1	CS210R-EH T=0.2	Matte Sn 80u" Min; Ni 40u" Min underplate		1
3	EARTH SPRING	CS210R-EH T=0.2	Matte Sn 80u" Min; Ni 40u" Min underplate		1
2	COVER	PA9T 94V-0	COLOR BLACK		1
1	HOUSING	PA9T 94V-0	COLOR BLACK		1

LZG INDUSTRIAL CO., LTD

PART NAME: WATERPROOF Ø3.5 PHONE JACK
 TOLERANCE UNLESS OTHERWISE SPECIFIED: 0.00±0.10

PART NO.: ZB23008-06SBAP-A

DRAWING: 林生财 DATE: 2020.02.18 SCALE: 1:1
 CHECK: 李楚鑫 DATE: 2020.02.18 MATERIAL: *

APPROVAL: 柳进宝 DATE: 2020.02.18 DWG. NO.:
 DRAWING NO.: ZB23008-06SBAP-A SHEET: 1/1