

RoHS
Compliant

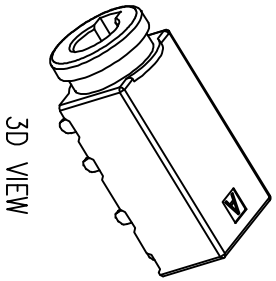

3D VIEW

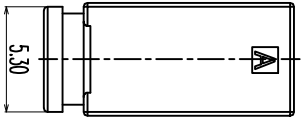
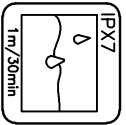

- NOTES
- CURRENT RATING: 1A.
 - CONTACT RESISTANCE: 100mΩ MAX.
 - INSULATION RESISTANCE: 100MΩ MIN.
 - DIELECTRIC WITHSTANDING: 500V AC MIN.
 - DURABILITY: 5000 CYCLES MIN.
 - CONNECTOR MATING FORCES: 3~30N.
 - CONNECTOR UNMATING FORCES: 3~30N.
 - OPERATING TEMPERATURE: -25°C TO +85°C.
 - WATERPROOF LEVEL: IP67

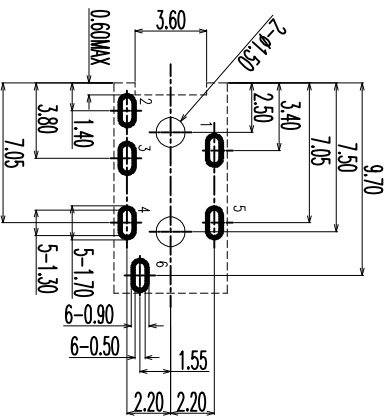
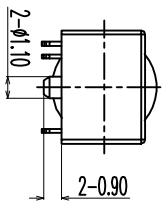
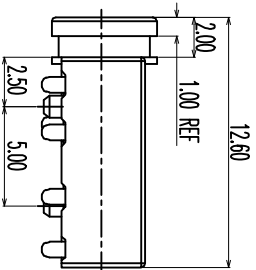
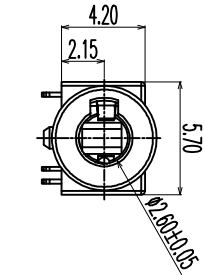

PCB LAYOUT (TOP VIEW)
TOLERANCE: ±0.05

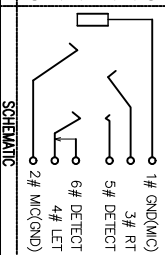
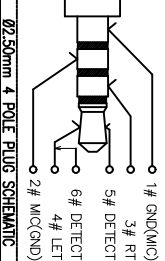
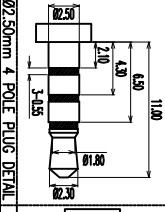
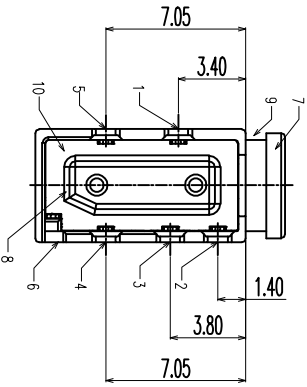

面接开孔参考尺寸

INSTALL WATERPROOF RING
(UNCOMPRESSED)

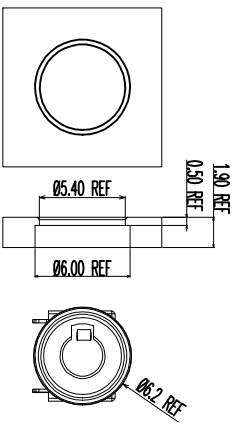

Not to install the waterproof ring shipment

NO.	DESCRIPTION	MATERIAL	REMARKS	QTY
10	GLUE	EPOXY	COLOR BLACK	1
9	WATERPROOF RING	SILICONE	COLOR BLACK	1
8	COVER	HIGH TEMPERATURE	COLOR BLACK	1
7	HOUSING	HIGH TEMPERATURE	COLOR BLACK	1
6	TERMINAL 6#	PHOSPHOR BRONZE	NICKEL UNDERPLATING OVERALL, GOLD FLASH PLATING ON THE SOLDER & CONTACT AREA	1
5	TERMINAL 5#	STAINLESS STEEL	NICKEL UNDERPLATING OVERALL, GOLD FLASH PLATING ON THE SOLDER & CONTACT AREA	1
4	TERMINAL 4#	STAINLESS STEEL	NICKEL UNDERPLATING OVERALL, GOLD FLASH PLATING ON THE SOLDER & CONTACT AREA	1
3	TERMINAL 3#	PHOSPHOR BRONZE	NICKEL UNDERPLATING OVERALL, GOLD FLASH PLATING ON THE SOLDER & CONTACT AREA	1
2	TERMINAL 2#	PHOSPHOR BRONZE	NICKEL UNDERPLATING OVERALL, GOLD FLASH PLATING ON THE SOLDER & CONTACT AREA	1
1	TERMINAL 1#	STAINLESS STEEL	NICKEL UNDERPLATING OVERALL, GOLD FLASH PLATING ON THE SOLDER & CONTACT AREA	1

LZG INDUSTRIAL CO. LTD

PART NAME: WATERPROOF 02.5 PHONE JACK
 TOLERANCE UNLESS 0.0±0.25
 OTHERWISE SPECIFIED: 0.00±0.10

PART NO.: ZB20002-06DBAP-A

UNIT: 0.1±2
 0.0±1
 0.00±0.5
 mm

DRAWING: 林生财 DATE: 2020.02.18 SCALE: 1:1
 CHECK: 李宏鑫 DATE: 2020.02.18 MATERIAL: *
 APPROVAL: 杨进宝 DATE: 2020.02.18 DWG. NO.:
 DRAWING NO.: ZB20002-06DBAP-A SHEET: 1/1